

DigiLED IR CA

WU-ST-005-DigiLED-IR-CA (Ref. No.: 186154)



A New Lighting Experience

1 Introduction

1.1 Product Description

DigiLED IR CA is designed to enable individual or pre-programmed control of the colour and brightness of LED modules within a 24 V CA LED assembly system. Control is "manual" via an infrared remote control with 6 keys.

The DigiLED IR CA system control unit is part of the 24 V CA LED assembly system and is used to control the light and colour of High- and/or LowPower RGB(W) modules that are constructed in accordance with the common anode principle (CA).

Scope of delivery:

- 1 x WU-ST-005-DigiLED-IR CA
- 1 x IR sensor PCB with 300 mm cable
- 1 x IR remote control

2 Description of Functions

2.1 Functional Characteristics

A DigiLED IR CA unit generates four PWM signals for colour control of LED modules within a 24 V CA LED assembly system. The four PWM signals are addressed via the keypad and pre-programmed sequences.

The following DigiLED IR CA functions can be adjusted:

- independent control of the brightness of single channels (RGBW)
- calling up and saving individual colour values (chromaticity)
- four different colour sequences (random colour changes, two soft RGB colour sequences, RGB sequence)

After mains voltage dis- and reconnection, DigiLED IR CA will restart with the last saved function (colour sequence or preset colour value).

2.2 Description of the Operating Elements

The IR remote control provides six keys that enable various functions:



2.2.1 Keys 1, 3 and 5 (Independent brightness control of individual RGB channels)

The light intensity of the respective colour channels (1=red, 3=green, 5=blue) can be adjusted with keys 1, 3 and 5. Pressing the respective key will increase brightness, whereby the length of time the key is held down will determine the brightness level. After the key is released the set brightness will remain until the key is pressed again, in which case the direction of brightness control will reverse. This reversal of brightness control will occur every time the key is pressed. A reduction in brightness is indicated by a short, single flashing of the connected LED assembly modules. The connected module will flash when the highest/lowest brightness point is reached.

2.2.2 Key 2 (Program speed)

Pressing the "program speed" key will change the speed of pre-programmed colour sequences. The length of time the key is pressed determines program speed. The direction of the speed adjustment reverses from "slower to quicker" and "quicker to slower" every time the key is pressed. A decrease in program speed is indicated by a short flash of the connected LED assembly module.

The connected module will flash when the highest/lowest speed has been reached.

2.2.3 Key 4 (Program mode, colour control channel 4)

a) Briefly pressing (< 1 s) key 4:

Various programs can be called up with key 4. Factory settings provide one "random" (program 1) and three "soft" pre-programmed colour sequences (programs 2, 3 and 4).

Fig. 1 shows the colour sequence of program 2.

Fig. 2 shows the colour sequence of program 3.

The colour sequence of program 4 is the same as for program 3, but channel 4 is additionally fully addressed (e.g. for white).

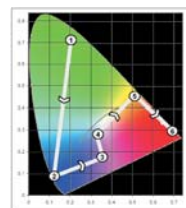

Fig. 1

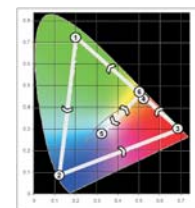

Fig. 2

Briefly pressing (< 1 s) the key calls up the programs in succession. After the key has been pressed, the current program is indicated by a respective flashing up of the connected LED assembly modules:

- one flash for program 1,
- two flashes for program 2,
- three flashes for program 3,
- four flashes for program 4.

b) Pressing and holding (> 1 s) key 4:

Pressing and holding key 4 (for longer than 1 second) enables the light intensity of channel 4 of the DigiLED IR CA unit to be adjusted to replicate the functions of keys 1, 3 and 5.

DigiLED IR CA

WU-ST-005-DigiLED-IR-CA (Ref. No.: 186154)

2.2.4 Key 6 (On/Off and Save)

Key 6 switches the connected LED modules on and off and also saves the current settings.

a) < 1 s:

Switches connected LED modules on and off. The saved colour value (according to b) will be recalled on start up.

b) > 3 s

Pressing key 6 for longer (> 3 sec) saves an individual colour value (from the program sequence or manual settings undertaken via keys 1, 3 and 5). The LED modules will flash briefly to show settings have been saved.

3 Technical Specifications

Operating voltage	23 to 25 V DC
Current draw	max. 5.0 A ± 5%
Fuse	T5A 250 V microfuse
Connection	6-pole push connector to connect IR sensor circuit board (see table 4.1) 8-pin push-in terminal for operating voltage and LED assembly modules of a 24 V CA system (see Table 4.2)
Ambient temperature	-20 to +45 °C
tc-Point	max. 55 °C
Degree of protection	IP 20
Casing	Plastic, PC, white
Dimensions (LxVxH)	95 x 60 x 30 mm
Weight	72 g

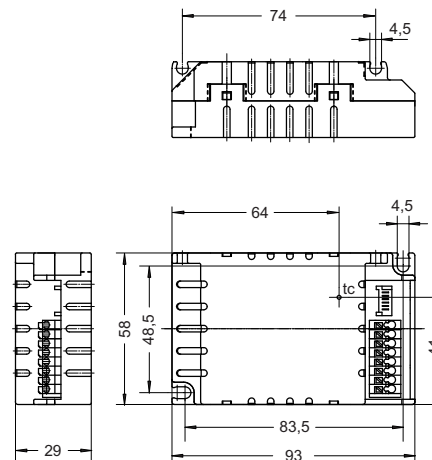

4 Terminal Connections

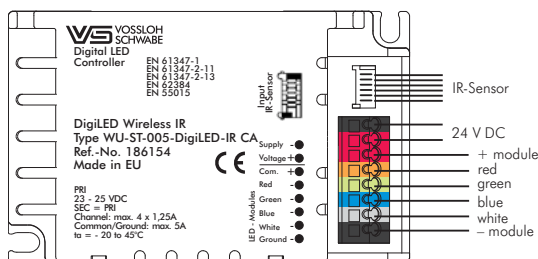

4.1 Push-in Terminal

	Function	Recommended Lead	Product
External switch	IR sensor circuit board	6-strand flatband cable	IR sensor circuit board

4.2 Terminal Strip for 24 V and Module Connections

Pole	Colour Coding	Max. Current-carrying Capacity	Function	Recommended Lead	Connection
1	● Black	5 A	Supply line for optional 24 V converter (GND)	Standard two-strand supply lead (0.5–1.5 mm ²)	24 V DC converter
2	● Red	5 A	Supply line for optional 24 V converter (+24 V)		
3	● Red	5 A	Supply line for LED assembly modules (+24 V)	High Power Feed-in-cable (Ref. No. 535900)	LED assembly modules or module groups for a 24 CA system
4	● Orange	1.25 A	PWM signal line for channel 1/red		
5	● Green	1.25 A	PWM signal line for channel 2/green	Standard six-strand lead (e.g. LIYY 6X0.75 mm ²)	or PCB distributor or slave board for a 24 V CA system
6	● Blue	1.25 A	PWM signal line for channel 3/blue		
7	● Grey	1.25 A	PWM signal line for channel 4/white		
8	● Black	5 A	Supply line for LED assembly modules (GND)		

DigiLED IR CA

WU-ST-005-DigiLED-IR-CA (Ref. No.: 186154)



5 DigiLED IR CA Connections

5.1 Input

- Voltage supply: DigiLED IR CA is supplied with 24 V DC via terminals 1 and 2.

5.2 Output

5.2.1 Connection of HighPower 24 V RGB(W) LED Assembly Modules

- a) The feed in cable (Ref. No. 535900) must be used to connect a HighPower 24 V RGB(W) LED assembly module. For direct connection, use terminals 3 to 8 of DigiLED IR CA.

Correct polarity (colour coding) must be ensure in accordance with Table 4.2.

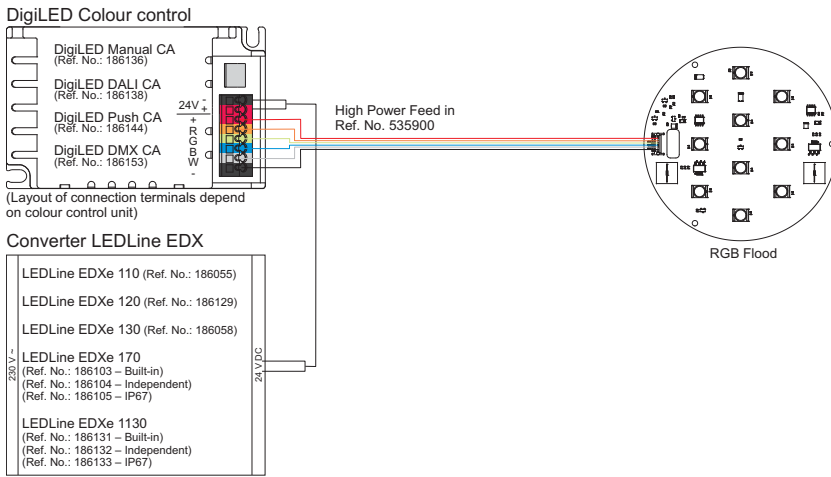

- b) To connect several HighPower 24 V RGB(W) LED assembly modules, the PCB distributor (Ref. No. 186141) must be connected to DigiLED IR CA using a standard six-strand lead (e.g. LIYY 6X0.75 mm²).

Correct polarity (colour coding) must be ensured in accordance with table 4.2. LED assembly modules are connected to the PCB distributor using flatband cables (Ref. No. 535898 or 535899).

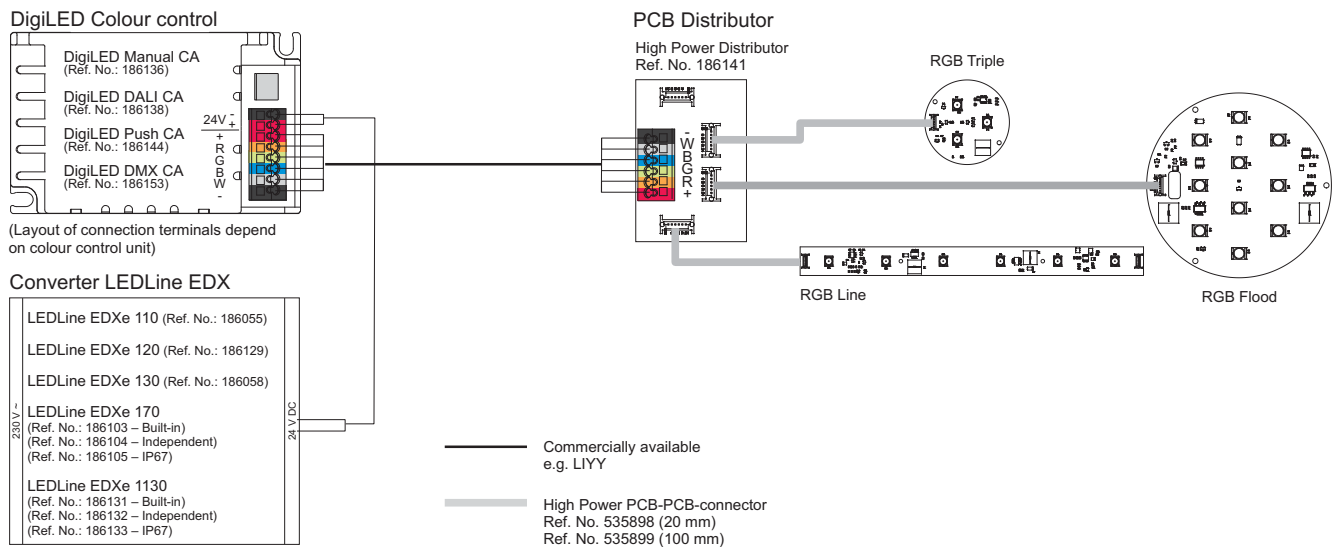

The maximum number of connected LED assembly modules is limited by the power rating of the converter and by the max. current load of the outputs in accordance with table 4.2. The power and current draw values of the connected LED assembly modules as well as connection cable and PCB distributor data can be found in the respective data sheets at www.vs-optoelectronic.com.

The maximum power rating for a DigiLED IR CA unit totals 120 W.

DigiLED IR CA

WU-ST-005-DigiLED-IR-CA (Ref. No.: 186154)



c) System performance can be extended beyond 120 W using slave boards to feed in additional power.

Functional descriptions and terminal connections for slave boards can be found in the respective data sheets at www.vs-optoelectronic.com.

Voltage Supply by first Converter

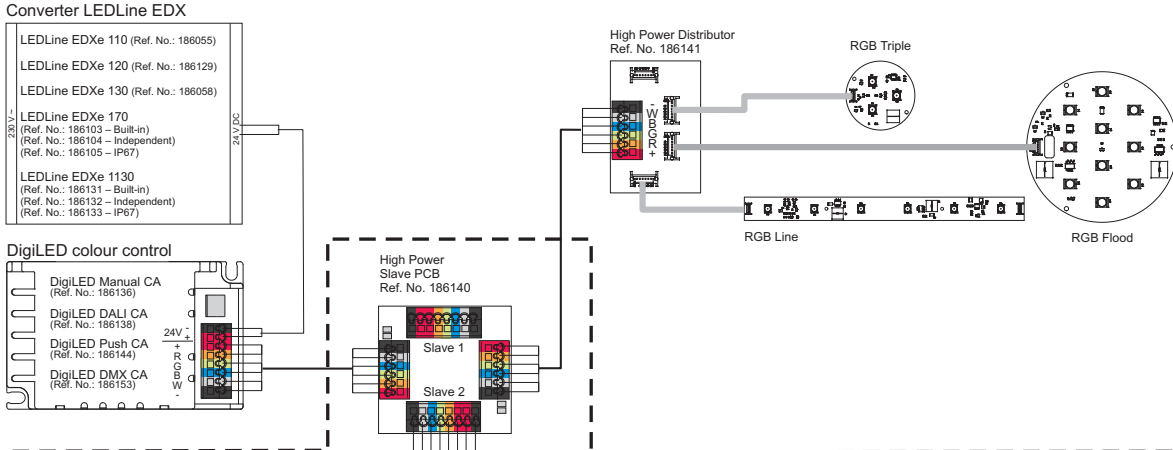

System Expansion by High Power Slave PCB and additional Converter

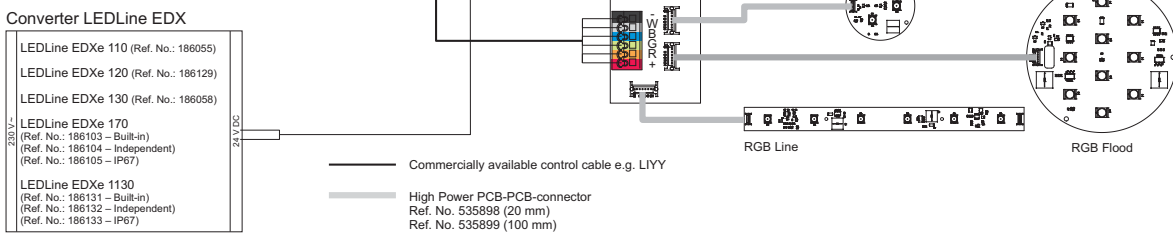

5.2.2 Connection of LowPower 24 V RGB CA Assembly Modules

LowPower 24 V RGB CA LED assembly modules with four connection elements (+RGB) can be directly connected to DigiLED IR CA via poles 3 (+), 4 (red channel), 5 (green channel) and 6 (blue channel) under observation of the permissible power rating. Compliance with the colour coding (polarity) detailed in table 4.2 must be ensured.

The maximum number of connected LowPower LED assembly modules is limited by the power rating of the connected converter and the maximum current load of pole 4, 5 and 6 (sum: 90 W) in accordance with table 4.2. The power and current draw values of the connected LED assembly modules can be found at www.vs-optoelectronic.com. The maximum power rating with which a DigiLED IR CA unit can be operated totals 90 W.

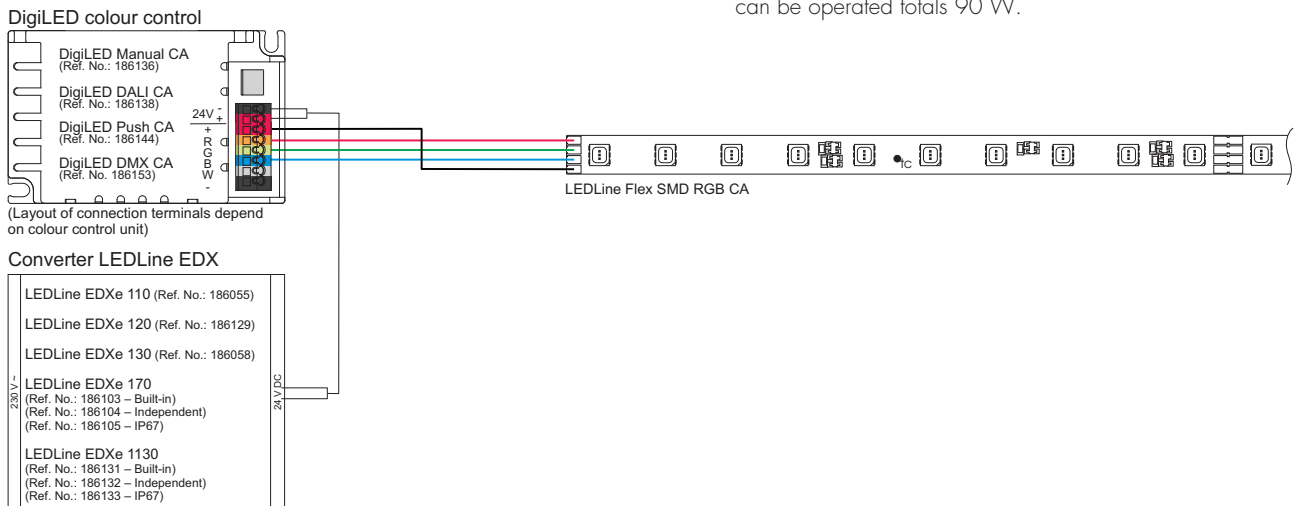

DigiLED IR CA

WU-ST-005-DigiLED-IR-CA (Ref. No.: 186154)



6 Notes on Installation and Safe Operation:

6.1 Installation

Installation must be carried out under observation of the relevant regulations and standards. The components of the 24 V CA system are designed for operation within a casing or luminaire. Installation must be carried out in a voltage-free state (i.e. disconnection from the mains). The following advice must be observed; non-observance can result in the destruction of the components, fire and/or other hazards:

- DigiLED IR CA is exclusively designed for operating 24 V Common Anode LED modules.
- The load range of the connected 24 V converter must be observed.
- The maximum output currents specified in Table 4.2 must not be exceeded.
- The temperature measured at the tc point must not exceed the specified limit ($t_{c,max.} = 55^{\circ}\text{C}$) during operation.

6.2 Assembly

- Installation any way up
- Installation only in dry rooms or luminaires, box casings or similar. If DigiLED IR CA is to be installed outdoors or in a damp location, a casing of a suitable protection class (IP) must be used.
- Attach using 4 mm screws
- Ensure solid and even surface for unit to rest on

7 Standards

7.1 Applied standards

EN 61347-1
Lamp controlgear – Part 1: General requirements and tests (IEC 61347-1:2000);
German Version EN 61347-1:2001
EN 61347-2-11
Lamp controlgear – Part 2-11: Particular requirements for miscellaneous electronic circuits used with luminaires (IEC 61347-2-11:2001);
German Version EN 61347-2-11:2001
EN 55015
Limits and methods of measurement of radio disturbance characteristics of electrical lighting and similar equipment

7.2 Standards to adhere

EN 61347-2-13
Lamp controlgear – Part 2-13: Particular requirements for D.C. or A.C. supplied electronic controlgear for LED modules
EN 62384
D.C. or A.C. supplied electronic control gear for LED modules – Performance requirements