



EXTENDER / EXTENDER 64



EXTENDER / EXTENDER 64

To extend the Blu2Light and LiCS Indoor System

The Extender can be used to extend the maximum number of DALI control gear units in a standard DALI system. This makes it possible to install the DALI Extender in place of a control gear unit, and to address it if necessary. Up to 64 DALI control gear units can be connected to the Extender output; each unit will respond in the same way depending on the input signal.

The Extender for DALI systems can only be used in connection with a DALI controller. With DALI commands, the Extender acts like a DALI ballast for fluorescent lamps.

As a full duplex repeater, the Extender 64 serves the purpose of system extension or lengthening DALI lines within a DALI system with up to 64 addresses. However, a maximum of three Extender 64 units can be connected per DALI system. Furthermore, the Extender 64 may be used only with control gear approved by Vossloh-Schwabe.

The Extender has a DALI bus supply on the output side, allowing connection of the maximum length of the DALI bus again in accordance with the standard.

The above-mentioned characteristics can be multiplied as often as required by connecting Extenders in series. This means the Extender is always used when large groups of DALI control gears are to be operated with the same signal at one DALI controller.

new >>

For larger applications, the Extender 64 also serves as a power supply for existing DALI applications to make them Blu2Light-enabled.



Overview of the LiCS Indoor System

Product matrix	Light Controller L / LS  for integration into the distribution board	Light Controller LW / LSW  for integration into the distribution board – EnOcean wireless version	Light Controller S  for independent operation	Light Controller XS  for independent operation
MultiSensors	 MultiSensors (motion and brightness)			
High Bay Sensors	 HB Sensors (motion) or brightness (constant light control)			
Extender				
Accessories	max. 6 buttons (mains voltage-compatible)	antenna (magnetic-base or screw-base); max. 6 buttons (mains voltage-compatible); EnOcean wireless modules (max. 16 pcs.)	button (mains voltage-compatible)	button (mains voltage-compatible)

Functions	Light Controller		Light Controller		Light Controller	Light Controller
	L	LS	LW	LSW		
Control options	single and group	group	single and group	group	broadcast	broadcast
No. of groups	max. 16		max. 16		—	—
No. of operating devices (DALI-EBs, LiCS-Extender, HB sensors)	max. 64		max. 64		max. 64	max. 10
No. of MultiSensors	max. 36		max. 36		max. 36	max. 4
Motion detection (automatic and semi-automatic)		●		●	●	●
Constant light control		●		●	●	●
Scene settings	●	—	●	—	—	—
Push function (on/off, up and down)		●		●	●	●
Dimming (only up or only down)		●		●	—	—
ON/OFF function		●		●	●	●
Overriding central control		●		●	—	—
Stairwell function (timer)		●		●	—	—
With integrated timer clock	—	●	—	●	—	—
Discourage burglaries	—	●	—	●	—	—
System analysis software		●		●	—	—
Password protection		●		●	—	—
Minimising standby losses		●		●	—	—
Menu navigation in	German, English, French, Italian, Spanish		German, English, French, Italian, Spanish		—	—
Configuration using	rotary push key and screen		rotary push key and screen		dip switch	dip switch

The values contained in this datasheet can change due to technical innovations. Any such changes will be made without separate notification.

Extender / Extender 64

To extend the Blu2Light and LiCS Indoor system

An extender enables the maximum number of DALI-compliant control gear units within a standard DALI system to be increased.

This means the DALI extender is installed and addressed in instead of the ballast. At the extender output, up to 64 DALI ballasts can then be connected, which will all respond in the same way to the respective input signal.

As a full duplex repeater, the Extender 64 serves the purpose of system extension or lengthening DALI lines within a DALI system with up to 64 addresses.

The extender for DALI systems can only be used in combination with a DALI controller. When DALI commands are received, the extender behaves just like a DALI-compliant ballast for fluorescent lamps.

Technical notes

Configuration interface: via a DALI controller
Ambient temperature t_a : 0 to 50 °C
Max. casing temperature t_c : 65 °C
Screw terminals: 0.75–2.5 mm²
Degree of protection: IP20, Protection class II
RFI-suppressed

Connections

Mains connection: 220–240 V AC/DC, 0/50–60 Hz
Max. power consumption: 6.5 W
For DALI signals in acc. with IEC 62386
DALI current consumption: 2 mA
1 DALI bus to 3 terminal pairs: max. current on the DALI bus = 200 mA (see the respective data sheet for current consumption values of the individual components)
As a standard DALI bus is not SELV-compliant, the DALI cable must be rated for mains voltage.
The DALI bus features reversible electronic overload and short-circuit protection.

Functions

Connection of up to 64 ballasts to a single DALI address

Extender

To extend DALI-controlled lighting systems
Dimensions (LxWxH): 175x42x31.5 mm
Weight: 150 g
Ref. No.: 186194

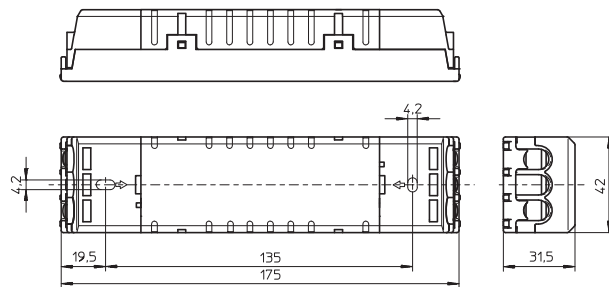

Extender 64 Functions

Range extension from 300 m by a further 300 m to a total of 600 m.
Power supply for existing DALI applications to make them Blu2Light-enabled.

Extender 64

Full duplex system extension
Dimensions (LxWxH): 175x42x31.5 mm
Weight: 150 g
Ref. No.: 186667

The values contained in this datasheet can change due to technical innovations. Any such changes will be made without separate notification.

General safety information

- LiCS products may only be installed and commissioned by authorised and fully qualified staff.
- These instructions must be carefully read before installing and commissioning the system, as this is the only way to ensure safe and correct handling.
- Before any work is carried out on the equipment, it must be disconnected from the mains.
- All valid safety and accident-prevention regulations must be observed.
- The products should never be inexpertly opened as this poses lethal danger due to electrical shock. Repairs may only be undertaken by the manufacturer.
- On no account may the DALI control line be used to carry mains voltage or any other external voltage as this can destroy individual system components.
- Please refer to the manual at www.vossloh-schwabe.com for exact instructions on how to configure the system using the Extender.

Extender / Extender 64

Installation

- Independent installation, e.g. in false ceilings
- Easy and time-saving installation due to end caps that snap into place without needing tools
- Clearance: min. 0.1 m to walls, ceilings, insulation and to other electronic devices; min. 0.25 m to sources of heat (e.g. lamps)
- Surface: solid, must not permit the extender to sink into insulation material
- Fastening: using 4-mm screws

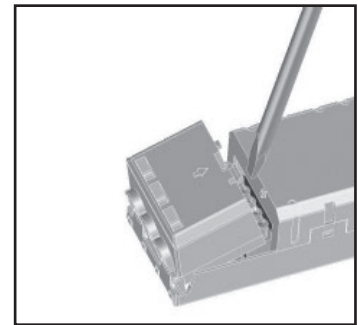

Installation instructions

- Cross-section of primary/secondary conductor: 0.75–2.5 mm²
- Cable preparation (see right)
- Screw terminals: max. tightening torque = 0.4 Nm
- Length of the secondary bus cable: max. 300 m
- A standard DALI bus only features basic insulation. All DALI cables must be rated for mains voltage. The power supply and the DALI line can be laid in a single cable (max. 100 m).
- Mains power cables and DALI cables should not be laid directly parallel to lamp cables (min. clearance = 0.25 m).
- A maximum of 64 DALI operating devices in total can be connected.
- Sensors must not be installed on the secondary side.
- A maximum of three Extender 64 units can be connected per DALI system.

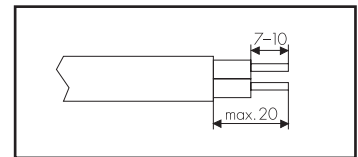

Additional information

- The Extender can only be operated if connected to a DALI control unit. Please refer to the respective operating instructions for information on the control unit.
- Only Extender (186194): The DALI Extender is integrated into the DALI system using the "random address" assignment method.
- Only Extender 64 (186667): Three electrically connected DALI outputs make it easier to connect DALI ballasts. A maximum of 64 DALI operating devices in total can be connected.
- The outputs of several extenders must not be connected with each other.
- Nur Extender (186194): All control gear that is connected to the output of the DALI Extender is synchronously operated in "broadcast" mode; the output side is not addressed.
- To ensure safe operation of the Extender, the maximum casing temperature at the measuring point (t_c) must not be exceeded.
- When using the Extender 64, the total number of 64 DALI addresses within the system may not be exceeded.
- The range extension achievable with the Extender 64 only applies in connection with VS DALI ballasts.

The values contained in this datasheet can change due to technical innovations. Any such changes will be made without separate notification.

Circuit diagram of the Extender

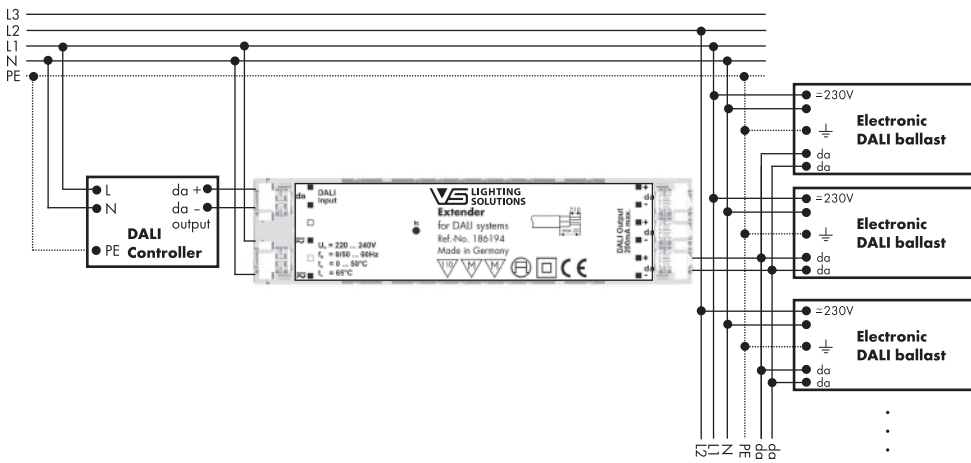

Circuit diagram Extender 64 in the Light Controller IP system

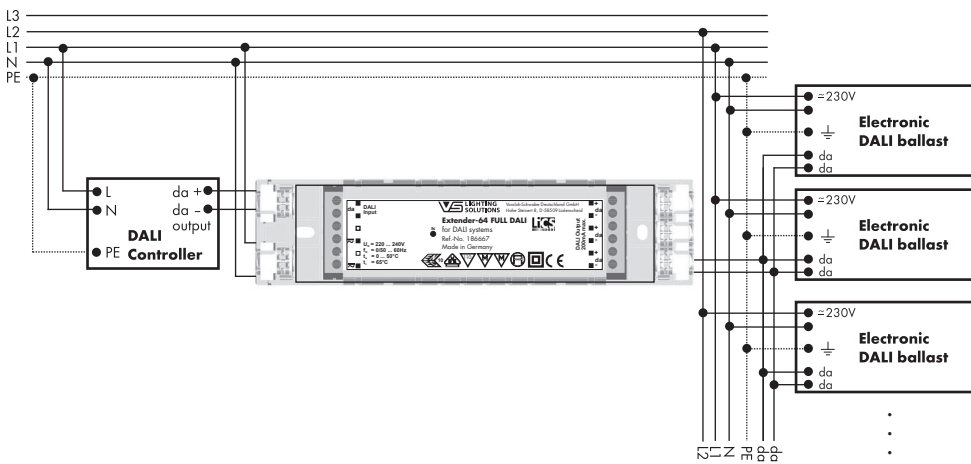

Circuit diagram Extender 64 in the Blu2Light-System

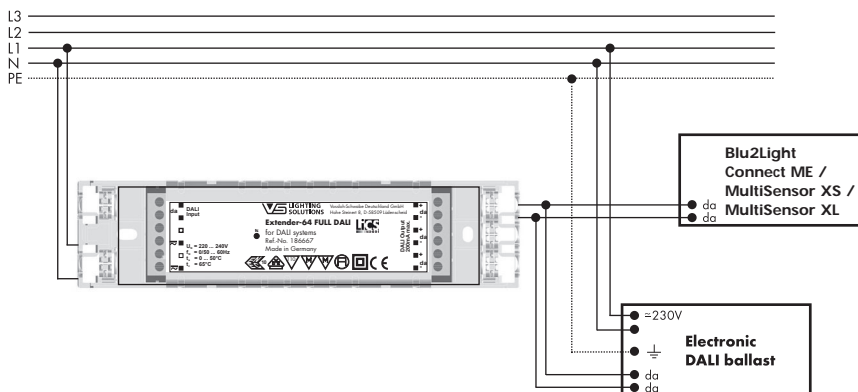

The values contained in this datasheet can change due to technical innovations. Any such changes will be made without separate notification.

Extender / Extender 64



Technical details

	Extender	Extender 64
Ref. No.	186194	186667
Supply voltage	220–240 V AC/DC, 0/50–60 Hz	
Power consumption	6.5 W	
Control input	DALI in. acc. with IEC 62386-102/-201	
DALI output	max. 64 pcs. DALI operating devices or max. 200 mA (expandable with the Extender)	
Ambient temperature t_a	0 to 50 °C	
Casing temperature t_c	max. 65 °C	
Degree of protection	IP20	
Protection class	II	
Weight	150 g	
CE requirements	EMC in acc. with EN 61547, RFI in acc. with EN 55015, Safety in acc. with EN 61347-2-11	

The values contained in this datasheet can change due to technical innovations. Any such changes will be made without separate notification.