

OPTIMISED LUMINAIRE PROTECTION



LUMINAIRE PROTECTION AND POWER ADJUSTMENT

This chapter presents inrush current limiters, electronic components to protect luminaires against mains surges, power reduction products and components with which the output current of LED drivers can be adjusted.



Luminaire Protection Device

For electronic devices

When electronic components form part of lighting systems, it is often necessary to protect such components against power-supply interruptions and electric overloads (power surges).

These can be caused by switching inductive loads or by atmospheric discharges such as lightning striking the mains or the ground. A further cause can be induced voltages from neighbouring cables when working with leading-edge phase-cutting controls.

The protection unit reduces over-voltages at the connection terminals of electronic components. The remaining residual voltage is then reduced to a respective protective level, based on the discharge current.

SP 230/10 K

Suitable for luminaires of protection class II

Type 3 product

With integrated thermal fuse

Dimensions (LxWxH): 32x22x13 mm

Weight: 20 g

Connecting: solid wire, length: 50 mm

Ref. No.: 147230

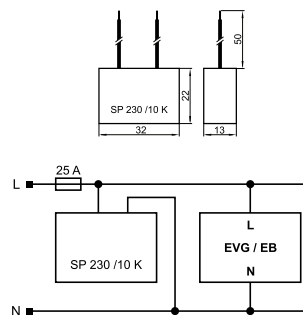

SPC 230/10 K

If the protective luminaire component overloads, the connected lighting circuit will be interrupted. This cut-out function makes it easier to detect the end of life of the protective component, facilitates quick replacement by maintenance staff and provides reliable protection for lighting components.

Suitable for luminaires of protection class II

Type 3 product

Dimensions (LxWxH): 53x28x27 mm

Weight: 50 g

Screw terminals: 0.5–1.5 mm²

Ref. No.: 142736

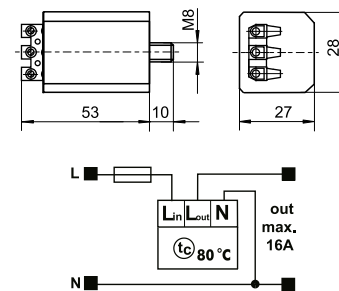

SP 3/230/10 K

Suitable for luminaires of protection class I

Type 3 product

Dimensions (ØxH): Ø 36x75 mm

Weight: 60 g

Screw terminals: 0.75–4 mm²

Ref. No.: 147233

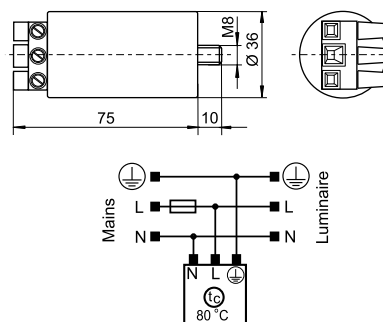

| Type | Ref. No. | Voltage 50/60 Hz V ± 10 % | Max. load current A | Max. impulse voltage U _{OC} (V) | Discharge current* (8/20 μs) I _N (A) I _{max} (A) | Protection level at discharge current of 1000 A | Safety max. A | Max. permitted casing temperature (°C) | Min. permitted ambient temperature (°C) | Fixation |
|---------------|---------------|---------------------------------|---------------------------|--|--|---|------------------|--|---|----------|
| SP 230/10 K | 147230 | 220–240 | — | 10000 | 5000 10000 | ≤ 850 V | 25 | 80 | –30 | — |
| SPC 230/10 K | 142736 | 220–240 | 16 | 10000 | 5000 10000 | ≤ 850 V | 16 | 80 | –30 | M8x10 |
| SP 3/230/10 K | 147233 | 100–277 | — | 10000 | 5000 10000 | ≤ 1000 V | 25 | 80 | –30 | M8x10 |

* Discharge current: at 5000 A min. 10 strikes; at 10,000 A min. 1 strike

The values contained in this data sheet can change due to technical innovations. Any such changes will be made without separate notification.

Luminaire Protection Device – Type 3

For electronic devices

These protective components are fitted with an LED indicator. Once the end of the component's life has been reached, the green LED goes out and the protective component has to be replaced.

SP230/10 K/HS/i

The green LED light will go out if the protective function fails

Dimensions (LxWxH): 90x17.2x63 mm

Weight: 45 g

Screw terminals: 0.5–2.5 mm²

Fixation on DIN installation rail

Ref. No.: 147240

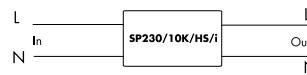
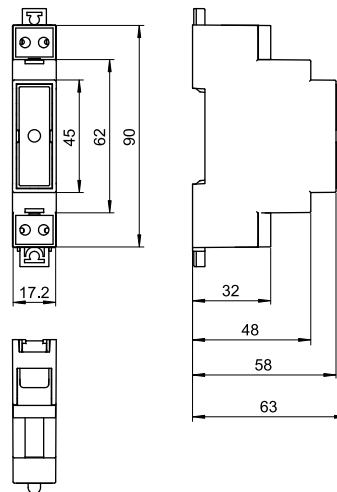

| Type | Ref. No. | Voltage 50/60 Hz V ±10 % | Max. load current (A) | Protection level at discharge current of 1000 A | Max. impulse voltage U _{OC} (V) | Discharge current* (8/20 μs) | | Safety | Max. permitted casing temperature °C | Fixation |
|-----------------|---------------|--------------------------------|--------------------------|---|--|---------------------------------|----------------------|--------|--|----------|
| | | | | | | I _N (A) | I _{max} (A) | max. A | | |
| SP230/10 K/HS/i | 147240 | 220–240 | 16 | ≤ 1000 V | 10000 | 5000 | 10000 | 16 | –35 to 80 | DIN-rail |

* Discharge current: at 5000 A min. 10 strikes; at 10,000 A min. 1 strike

The values contained in this data sheet can change due to technical innovations. Any such changes will be made without separate notification.

Luminaire Protection Device – Type 3

For electronic devices

These protective components are fitted with internal thermal fuses. The protective component will be disconnect from the mains at the end of the internal varistors' life or if there is a permanently overvoltage.

In that case the green LED goes out and the protective component has to be replaced.

AC-system: TTTN-IT

Temporary overvoltage

(TOV)-LV: 443 V AC (5 sec.) / 443 V (120 min.)

(TOV)-MV/HV: 1200 V AC (200 msec.)

I_{scrr} : 1000 A

With integrated thermal fuse

Dimensions (LxWxH): 79x45x35 mm

SP3/230/10K/i

Suitable for luminaires of protection class I

Push-in terminals: 0.5–2.5 mm²

Degree of protection: IP20

DEKRA approved acc. to EN 61643-11

Weight: 67/72 g

Ref. No.: 142743 without fixing threaded bolt

Ref. No.: 142744 with fixing threaded bolt



Powered by DEKRA

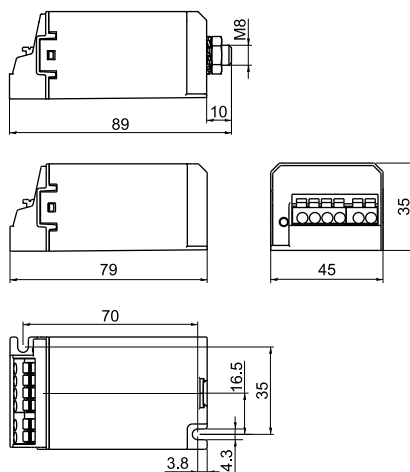

SPC3/230/20K/i

Suitable for luminaires of protection class I

Push-in terminals: 0.75–2.5 mm²

Degree of protection: IP20

Comply with the requirements of EN 61643-11

Weight: 55/60 g

Ref. No.: 142752 without fixing threaded bolt

Ref. No.: 142751 with fixing threaded bolt

SP3 230/10K/i

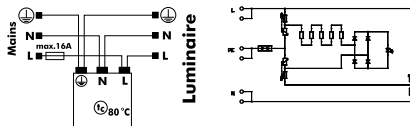

SPC3/230/20K/i

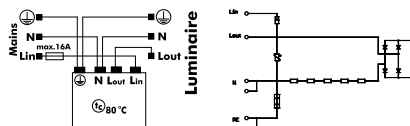

| Type | Ref. No. | Voltage 50/60 Hz V ±10 % | Max. load current (A) | Protection level | I_{pe} | Max. impulse voltage U_{oc} (V) | Discharge current* (8/20 μ s) | Safety | Max. permitted casing temp. °C | Fixing threaded bolt |
|-----------------|---------------|--------------------------------|-----------------------------|-------------------------------|----------|---|--------------------------------------|--------|--------------------------------------|----------------------------|
| | | | | L-N (V) L-PE (V) N-PE (V) | μ A | | I_N (A) I_{max} (A) | max. A | | |
| SP3/230/10 K/i | 142743 | 100–277 | 16 | < 1500 < 1800 < 1800 | 1 | 10000 | 5000 10000 | 16 | –35 to 80 | without |
| SP3/230/10 K/i | 142744 | 100–277 | 16 | < 1500 < 1800 < 1800 | 1 | 10000 | 5000 10000 | 16 | –35 to 80 | with |
| SPC3/230/20 K/i | 142751 | 100–277 | 16 | < 1800 < 2200 – | 1 | 20000 | 10000 20000 | 16 | –35 to 80 | with |
| SPC3/230/20 K/i | 142752 | 100–277 | 16 | < 1800 < 2200 – | 1 | 20000 | 10000 20000 | 16 | –35 to 80 | without |

* Discharge current: at I_N min. 10 strikes; at I_{max} . 1 strike

The values contained in this data sheet can change due to technical innovations. Any such changes will be made without separate notification.

Luminaire Protection Device – Type 3

For electronic devices

These protective components are fitted with an LED indicator. Once the end of the component's life has been reached, the green LED goes out and the protective component has to be replaced.

If the protective luminaire component overloads, the connected lighting circuit will be interrupted. This cut-out function makes it easier to detect the end of life of the protective component, facilitates quick replacement by maintenance staff and provides reliable protection for lighting components.



Powered by DEKRA

AC-system: TT/NT

Temporary overvoltage

(TOV)-LV: 443 V AC (5 sec.) / 443 V (120 min.)

(TOV)-MV/HV: 1200 V AC (200 msec.)

I_{scrr}: 4500 A

With integrated thermal fuse

DEKRA approved acc. to EN 61643-11

Dimensions (LxWxH): 76x34x27 mm

Weight: 100 g

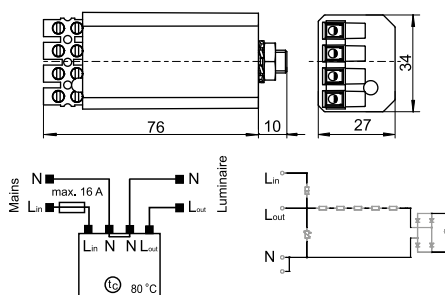

SPC 230/10 K/i

SPC 230/10 K/i

Suitable for luminaires of protection class II

Screw terminals: 0.75–2.5 mm²

Degree of protection: IP20

Ref. No.: 142737

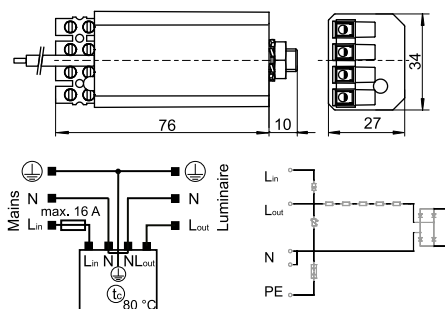

SPC 3/230/10 K/i

SPC 3/230/10 K/i

Suitable for luminaires of protection class I

Screw terminals: 0.75–2.5 mm²

Lead ground terminal: stranded conductors, 2.5 mm², silicone insulation, length: 150 mm

Degree of protection: IP20

Ref. No.: 142738

Earthing wire with M4 ring-tongue

Ref. No.: 142742

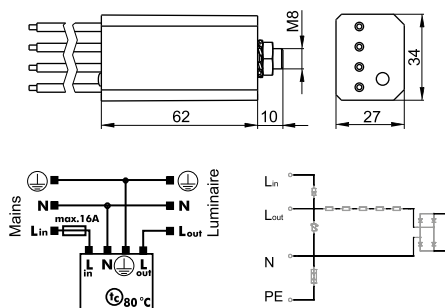

SPC 3/230/10 K/i-IP66

SPC 3/230/10 K/i-IP66

4 leads: stranded conductors, 2.5 mm²,

silicone insulation, length: 150 mm

Degree of protection: IP66

Ref. No.: 142748

| Type | Ref. No. | Voltage 50/60 Hz V ±10 % | Max. load current (A) | Protection level | | I _{pe} μA | Max. impulse voltage U _{OC} (V) | Discharge current* (8/20 μs) | | Safety max. A | Max. permitted casing temp. °C | Fixation |
|-----------------------|----------|--------------------------------|-----------------------------|------------------|----------|-----------------------|--|---------------------------------|----------------------|------------------|--------------------------------------|----------|
| | | | | L-N (V) | L-PE (V) | | | I _N (A) | I _{max} (A) | | | |
| SPC 230/10 K/i | 142737 | 100–277 | 16 | < 1500 | – | – | 10000 | 5000 | 10000 | 16 | –35 to 80 | M8x10 |
| SPC 3/230/10 K/i | 142738 | 100–277 | 16 | < 1500 | < 1800 | 1 | 10000 | 5000 | 10000 | 16 | –35 to 80 | M8x10 |
| SPC 3/230/10 K/i | 142742 | 100–277 | 16 | < 1500 | < 1800 | 1 | 10000 | 5000 | 10000 | 16 | –35 to 80 | M8x10 |
| SPC 3/230/10 K/i-IP66 | 142748 | 100–277 | 16 | < 1500 | < 1800 | 1 | 10000 | 5000 | 10000 | 16 | –35 to 80 | M8x10 |

* Discharge current: at 5000 A min. 10 strikes; at 10,000 A min. 1 strike

The values contained in this data sheet can change due to technical innovations. Any such changes will be made without separate notification.



Inrush Current Limiter ESB

Limits capacitive inrush currents of electronic ballasts and LED drivers and converters

Due to their capacitive nature, electronic operating devices generate high inrush currents. By temporarily activating a limiting resistor, the inrush current is reduced to an uncritical value (see graph below).

Several electronic devices can be connected downstream under consideration of the maximum permissible continuous current of the inrush current limiter. As a result, the load per circuit breaker (MCB) can be increased by at least 2.5 fold.

The ESB thus prevents any automatic circuit breakers from being triggered or any damage from being caused to upstream relay contacts. Switching cycles: > 10,000

ESB-6K

Casing: PC
Dimensions (LxWxH): 55x28x27 mm
Weight: 61 g
Screw terminals: 0.5–1.5 mm²
VDE approved

Ref. No.: 149820
Ref. No.: 149822

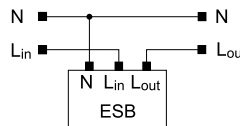
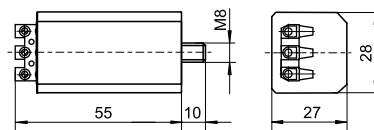

ESB-16HS

Casing: PC
Dimensions (LxWxH): 90x18x58 mm
Weight: 75 g
Screw terminals: 0.5–2.5 mm²

Ref. No.: 149821

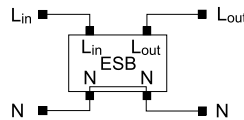
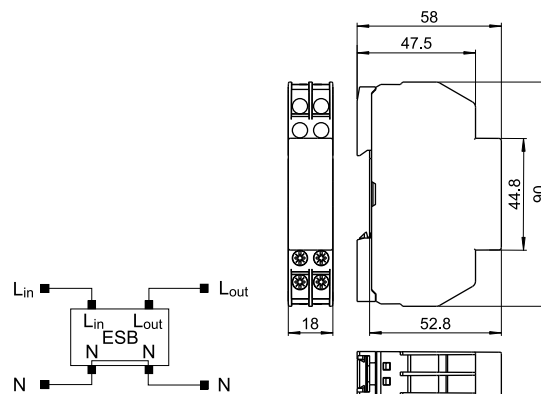

| Type | Ref. No. | Nominal voltage 50–60 Hz V ± 10 % | Power consumption W | Max. direct current A | Limiting resistor Ω | Period of limitation ms | Max. permitted casing temperature (°C) | Min. permitted ambient temperature (°C) | Fixation |
|-----------|---------------|---|------------------------|--------------------------|------------------------|----------------------------|--|---|----------|
| ESB-6K | 149820 | 220–240 | 0.25 | 6 | 20 | approx. 18 | 80 | –30 | M8x10 |
| ESB-16HS | 149821 | 220–240 | 0.6 | 16 | 11.2 | approx. 18 | 80 | –30 | DIN-rail |
| ESB-6K_1A | 149822 | 220–240 | 0.25 | 6 | 440 | approx. 160 | 80 | –30 | M8x10 |

Example using a 150 W LED driver

Brown: with ICL (ESB)
Blue: without ICL (ESB)
1 V = 1 A

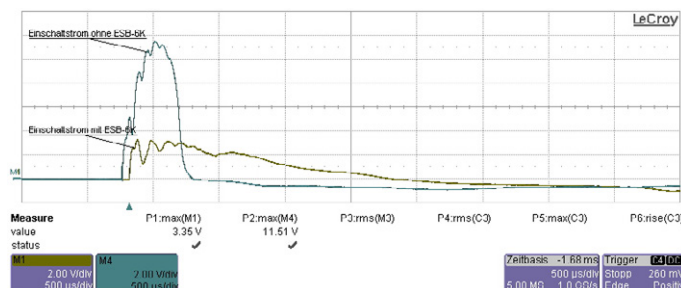

The values contained in this data sheet can change due to technical innovations. Any such changes will be made without separate notification.

Automatical Power Switch for LED Drivers – PR 12 K LC

The PR 12 K LC can be used for power switching of LED drivers with LST control input. A control phase is not needed. Once it's connected to the mains supply voltage the power switch will switch automatically.

The power switch complies with the specification of DIN EN 61347 and is suitable for the application in luminaires of protection class I and II.



PR 12 K LC

Casing: PC
 Dimensions (LxWxH): 76x34x30 mm
 Weight : 100 g
 Screw terminals: 0.75–2.5 mm²
Ref. No.: 142170

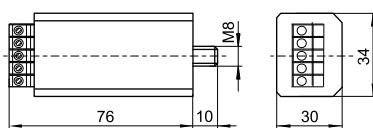

Wiring diagram

For example with VS LED drivers ECXd 700.023 (Ref. No. 186509)

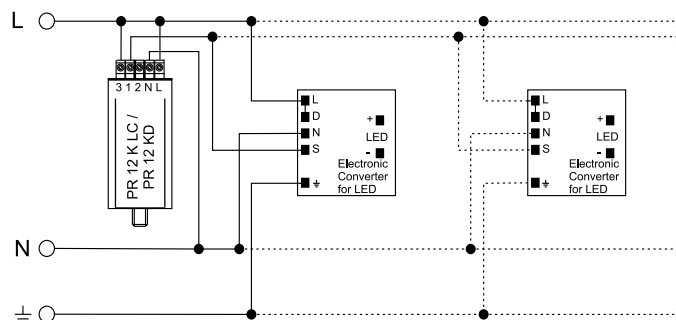

| Type | Ref. No. | Nominal voltage/frequency V ±10% | Max. switching capacity (VA) | Max. contact current (A) $\lambda = 0.5$ $\lambda = 1$ | Internal loss W | Inherent heating K | Switching-time | Max. permitted casing temperature (°C) | Min. permitted ambient temperature (°C) | Fixation |
|------------|---------------|-------------------------------------|------------------------------|---|--------------------|-----------------------|----------------|--|---|----------|
| PR 12 K LC | 142170 | 220–230 V/50 Hz 220 V/60 Hz* | 3000 | 8 12 | < 1 | < 12 | selectable | 80 | –30 | M8x10 |

* 120–240 V ±10% available on request

The values contained in this data sheet can change due to technical innovations. Any such changes will be made without separate notification.

Programmable Power Switch for LED Drivers – PR 12 KD

The PR 12 KD can be used for power switching of LED drivers with LST control input. A control phase is not needed. The constant switching-time is selectable.

The left side of the rotary switch is used for reset to full power after eleven hours; the right side is for continuous power reduction after programmed time has been reached.

The power switch complies with the specification of DIN EN 61347 and is suitable for the application in luminaires of protection class I and II.

PR 12 KD

Casing: PC
Dimensions (LxWxH): 76x34x30 mm
Weight: 100 g
Screw terminals: 0.75–2.5 mm²

Ref. No.: 142150

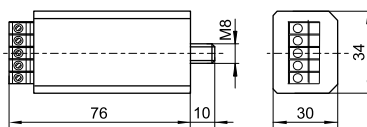
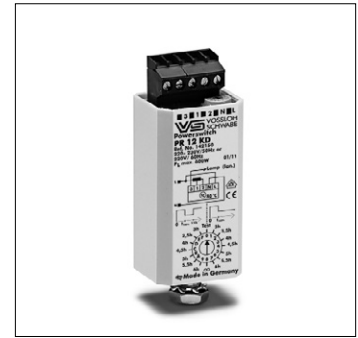

Wiring diagram

For example with VS LED drivers ECXd 700.023 (Ref. No. 186509)

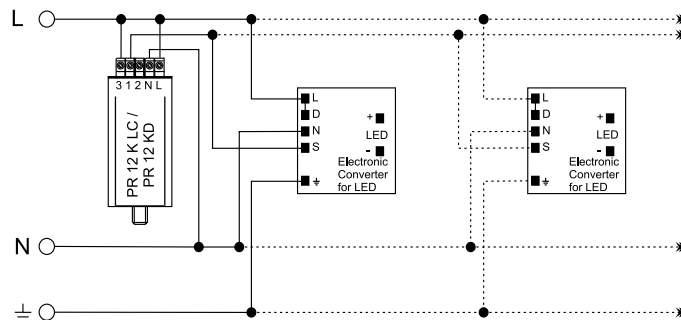

| Type | Ref. No. | Nominal voltage/frequency V ±10% | Max. switching capacity (VA) | Max. contact current (A) $\lambda = 0.5$ $\lambda = 1$ | Internal loss W | Inherent heating K | Switching-time* | Max. permitted casing temperature (°C) | Min. permitted ambient temperature (°C) | Fixation |
|----------|---------------|-------------------------------------|------------------------------|---|--------------------|-----------------------|-----------------|--|---|----------|
| PR 12 KD | 142150 | 220–230 V/50 Hz 220 V/60 Hz** | 3000 | 8 12 | < 1 | < 12 | selectable | 80 | –30 | M8x10 |

* Switching-time selectable: 3 | 3.5 | 4 | 4.5 | 5 | 5.5 | 6 hrs. at 50 Hz

** 120–240 V ±10% available on request

The values contained in this data sheet can change due to technical innovations. Any such changes will be made without separate notification.

Switch Units for Electronic Operating Devices with 1-10 V Interface

Vossloh-Schwabe's switch units are designed to enable one-step power reduction of lamps (FL, CFL, LED, HS, HI and C-HI) with the help of the respective electronic ballast or converter.

To this end, the switch unit utilises the 1-10 V interface of the control gear unit. The switch unit is mainly intended for outdoor luminaires in systems with or without a control phase.

Dimensions (LxWxH): 56x28x27 mm

Casing: PC

Screw terminals: 0.75-2.5 mm²

Max. permissible casing temperature t_c : 80 °C

Min. permissible ambient temperature t_a : -30 °C

Fastening: plastic male nipple with pre-assembled washer and nut

Power reduction SU 1-10 V K for lighting systems featuring an L_{ST} control phase

The switch unit employs a positive switching to reduce power, i.e. power is reduced when the control phase is switched off ($L_{ST} = 0$ V).

The 1-10 V interface of the electronic ballast is addressed at the moment that power reduction is effected.

Power reduction PR 1-10 V K LC for lighting systems without a control phase

This switch unit can be used to effect power reduction in lighting systems that do not feature a control phase. The 1-10 V interface is addressed on the basis of the fundamental operating principle used by Vossloh-Schwabe's PR 12 K LC power switch (details of which can be made available on request). This power switch is capable of determining the starting time of reduced-power operation over the measured operating time of a lighting system. As a result, it is no longer necessary to spend valuable time modifying the power-reduction unit to suit the continually changing day-night cycle; changing the clocks in line with daylight saving measures in the summer and winter is equally unnecessary. The 1-10 V interface of the electronic ballast is addressed as soon as the system is switched to reduced power.

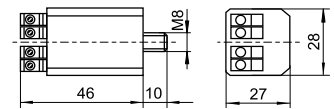

Circuit diagram SU 1-10 V K

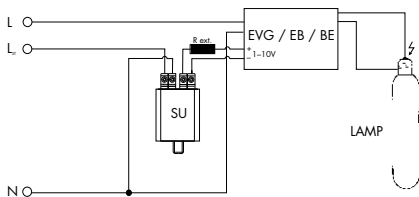

Circuit diagram PR 1-10 V K LC

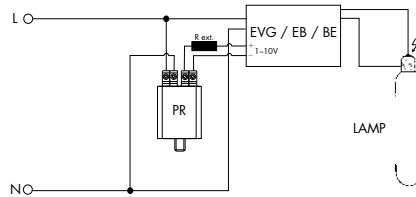

| Type | Ref. No. | Control voltage L _{ST} V, 50/60 Hz | Externally (on site) connected resistor (R _{ext.}) kΩ (min. 0.1 W) | Inherent heating K | Weight g |
|---|----------|--|---|-----------------------|-------------|
| For lighting systems with control phase | | | | | |
| SU 1-10 V K | 149992 | 220-240 V ±10% | 1-70 | < 10 | 50 |
| For lighting systems without control phase | | | | | |
| PR 1-10 V K LC | 149993 | — | 1-70 | < 10 | 50 |

The values contained in this data sheet can change due to technical innovations. Any such changes will be made without separate notification.

Resistor Network for LED Drivers

This resistor network is used to adjust the output currents of LED drivers. 255 different resistance values can be adjusted in 10-Ohm steps within a range from 0 to 2550 Ohm by connecting the SU 1–10 V K and PR 1–10 V LC power switches. As an example, this makes it possible to even out differences in luminous flux common to LED luminaires.

The component is designed for use in protection class II luminaires.



R10-1280

Casing: PC

Dimensions (LxWxH): 32x25x15 mm

Weight: 20 g

Connection leads, solid: 0.5 mm²

Lead length: 150 mm

Ref. No.: 149800

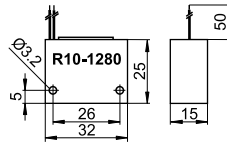

R6,25K-70K

Resistor network for LEDset interface

Casing: PC

Dimensions (LxWxH): 32x25x15 mm

Weight: 20 g

Connection leads, solid: 0.5 mm²

Lead length: 150 mm

Ref. No.: 149802

| Type | Ref. No. | Number of dip switch V, 50/60 Hz | Max. internal loss of resistors W | Max. voltage at resistors V | Max. permitted casing temperature (°C) | Min. permitted ambient temperature (°C) |
|------------|---------------|----------------------------------|-----------------------------------|-----------------------------|--|---|
| R10-1280 | 149800 | 8 | 0.25 | 200 | 80 | -30 |
| R6,25K-70K | 149802 | 8 | 0.25 | 200 | 80 | -30 |

The values contained in this data sheet can change due to technical innovations. Any such changes will be made without separate notification.