

iMCU

INTELLIGENT MULTIFUNCTIONAL CONTROLLER UNITS

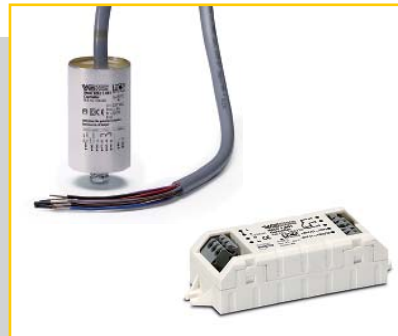

Designed for use with street lighting and lighting near buildings, the controller enables control of magnetic and electronic ballasts with 1 to 10 V and DALI interface. It can be individually programmed and updated and, when in use, provides all the functions of a light management system, but it does this in stand-alone operation without requiring complex commissioning.

Other advantages

- 10 dimming levels with individual dimming sequences
- Stand-by loss: < 0.5 W
- Delayed switching-on and early switching-off with individual dimming sequences
- Control input can be adjusted to perform different tasks
- Intuitive software-based configuration
- Luminaire can be switched off if connected to a switched lighting cable
- Simple configuration transfer using a USB interface converter or a manual programming device
- Burning-in of high-pressure discharge lamps following lamp exchange
- Remote parameter functions
- Connections for various motion sensors, key switches and light sensors
- Extremely small dimensions for use in compact LED luminaires
- Automatic, random and delayed switching-on of electronic ballasts in a maximum of 15 groups to distribute inrush current peaks.
- Thermal management for temperature-dependent control of the luminaire regardless of the electronic ballast chosen.
- Non-linear, adjustable maintenance value with 5 interpolation points
- Automatic summer/winter time changeover
- Remote parameter function:
Change of parameter settings of the weather-dependent time and dimming values by means of power supply line switch-on cycles
- 5 years warranty

Typical applications

- Street lighting and lighting in the vicinity of buildings
- Outside illuminated zones at pedestrian crossings
- Car parks, bus stops and stations
- Company premises, warehouses
- Sports facilities

Light Controller iMCU

Technical data

Electronic light controller	186232	186338
Type	iMCU IP20	iMCU IP67
Input voltage	230 V AC \pm 10% AC	230 V AC \pm 10% AC
Mains frequency	50 Hz (+1% / -2%)	50 Hz (+1% / -2%)
Power consumption	< 0.5 W; PF = 0.1	< 0.5 W; PF = 0.1
Electrical isolation	No electrical isolation between input and output (when the electronic ballast is connected to the iMCU, the control input is no longer electrically isolated)	No electrical isolation between input and output (when the electronic ballast is connected to the iMCU, the control input is no longer electrically isolated)
Switching current	4 A, λ = 0.8	4 A, λ = 0.8
Switching cycles	50.000 switching operations per function (I, λ)	50.000 switching operations per function (I, λ)
Programmable	Yes	Yes
Configurable parameters	Yes	Yes
Control output 1–10 V	Short-circuit proof	Short-circuit proof
Control output DALI	Short-circuit proof, 2 mA designed for use as slave	Short-circuit proof, for max. of 1 electronic ballast
Terminals	0.5 to 1.5 mm ²	8-wire cable, 600 mm
Terminal conductor type	Single-core, stranded	Single-core, stranded
Firmware update / parameter setting	With iMCU configuration tool using universal input while disconnected from the mains	With iMCU configuration tool using universal input while disconnected from the mains
Working temperature range t_{wv}	-25°C to +80°C	-25°C to +80°C
Storage temperature range	-25°C to +85 °C	-25°C to +85 °C
Air humidity	90% non-condensing	non-condensing
Surge voltage protection	4 kV / 1.2 / 50 in acc. w. DIN EN 61037	4 kV / 1.2 / 50 in acc. w. DIN EN 61037
Type of protection	IP20	IP67
Protection class	Suitable for luminaires of protection classes I and II	Suitable for luminaires of protection classes I and II
Casing material	PC	Aluminium
Dimensions (W x H x D)	83 x 19 x 30 mm	85 x \varnothing 45 mm
Weight	32 g	
Country of origin	Made in Germany	Made in Germany

Dimensions IP20 version

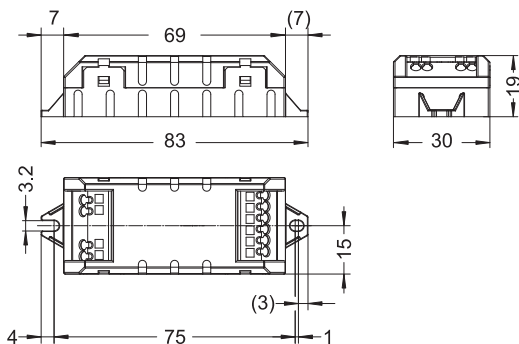

Dimensions IP67 version

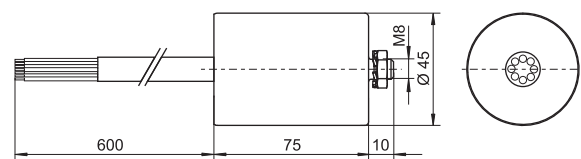

Light Controller iMCU

Controller versions are available for installation in the luminaire or in the mast. The 1–10 V/DALI output is designed for controlling an electronic ballast to achieve the lowest stand-by loss of < 0.5 W. When an electronic ballast is connected to the controller, the digital control input is no longer electrically isolated. In addition to changes of parameter settings of the various applications, the microcontroller enables complete firmware updates to be ready for future adjustment such as to the DALI standard. Disclosure of OEM and customer-specific versions can be prevented by means of a special software key. Please ask your VS contact for details about this function. When the electronic ballast is connected to the iMCU, the control input is no longer electrically isolated.

Block diagram

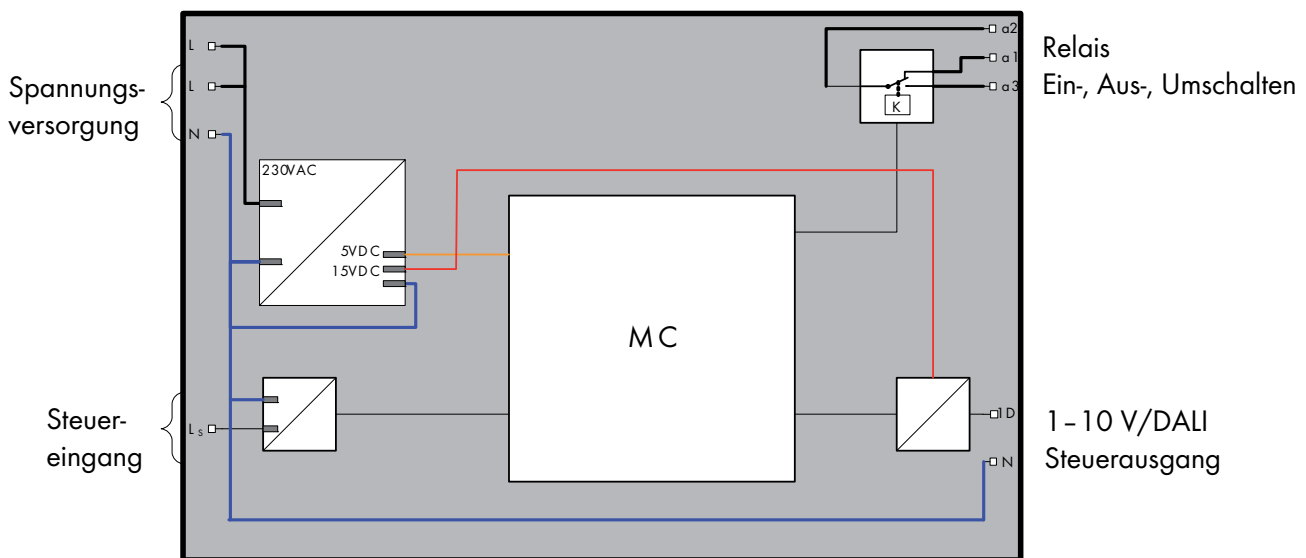

Functions

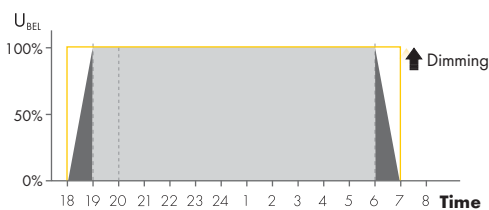

DOO (Dimmed ON/OFF)

Dimming sequences can be used to switch lighting to the desired brightness and also to switch lighting off.

The brightness of modern LED luminaires can also be increased slowly up to a defined light level immediately after they have been switched on. This function enables the configuration of an up to 36 minutes long dimming sequence.

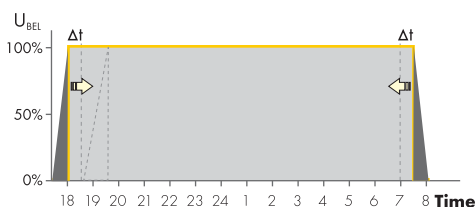

DPC (Delayed Switching for Pedestrian Crossing)

Delayed switching-on and early switching-off of lighting near pedestrian crossings.

Lighting at pedestrian crossings is typically to be switched at 40 lx, while outside such areas lighting is switched only at lower lux levels. If the cabling infrastructure required for this kind of control does not exist, the iMCU controller can simulate a similar behaviour thanks to its ability to learn. The pedestrian crossing area can be switched and time-delayed. The remaining lighting can be switched and/or dimmed independently based on a learning function.

The values specified in this data sheet may change due to technical innovation and without notice.
For more detailed information visit www.vossloh-schwabe.com.

Light Controller iMCU

Functions (continued)

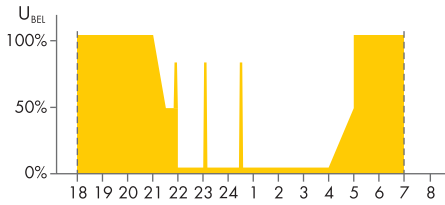

ISD (Intelligent Switching Time Dimming)

Intelligent, timer-controlled periods of dimmed light

A season-specific reference value is derived from the period of time the lighting cable is switched on. Based on the reference value, the controller can control the lighting system with up to 10 dimming levels and dimming sequences. Accidental (erroneous) configurations that can arise, for instance, during maintenance work, are successfully suppressed by the controller as it ignores short lighting periods of less than 6 hours and long periods of more than 18 hours.

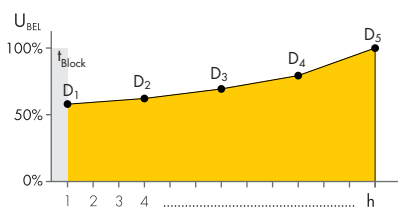

MFF (Maintenance Factor Function)

Maintenance factor function: Control of the luminous flux decrease over the lamp's service life

Lamps, mirrors and glass luminaire covers are subject to ageing. This process is compensated by controlling the luminous intensity during the lamp's service life, so that a constant luminous flux can be generated. If it is known how much the luminous flux decreases over service life, the process can be equalised and energy costs can be saved. This function can also be used to precisely adjust the luminaire to the lighting task where otherwise the lighting level would be too high as a result of the replacement of the lamp.

T_{Block}

Period of time during which a lamp is burned in, i.e. the time during which it must not be dimmed (typically 100 hours).

T_n

Service life of the lamp expressed in n x1000 hours.

D1

Dimming value at the time of commissioning. The value set is stated in %.

D2, D3, D4,

Configurable dimming values according to the ageing of the lamp, stated in %.

D5

Dimming value at the end of the lamp's service life. The value is stated in %.

The values specified in this data sheet may change due to technical innovation and without notice.
For more detailed information visit www.vossloh-schwabe.com.

Light Controller iMCU

Configuration and graphical user interface

Despite being a highly complex piece of technology, the light controller's intuitive software interface makes it both user-friendly and easy to configure. The GUI enables direct configuration via a USB interface. Alternatively, the configuration process can also be transferred to a hand-held programming device, which means that the parameters of a luminaire can be reconfigured even without a PC or notebook (see Accessories, p. 8). The integrated power supply of the programming device means configuration updates can be undertaken even when the power supply is disconnected.

Function diagram

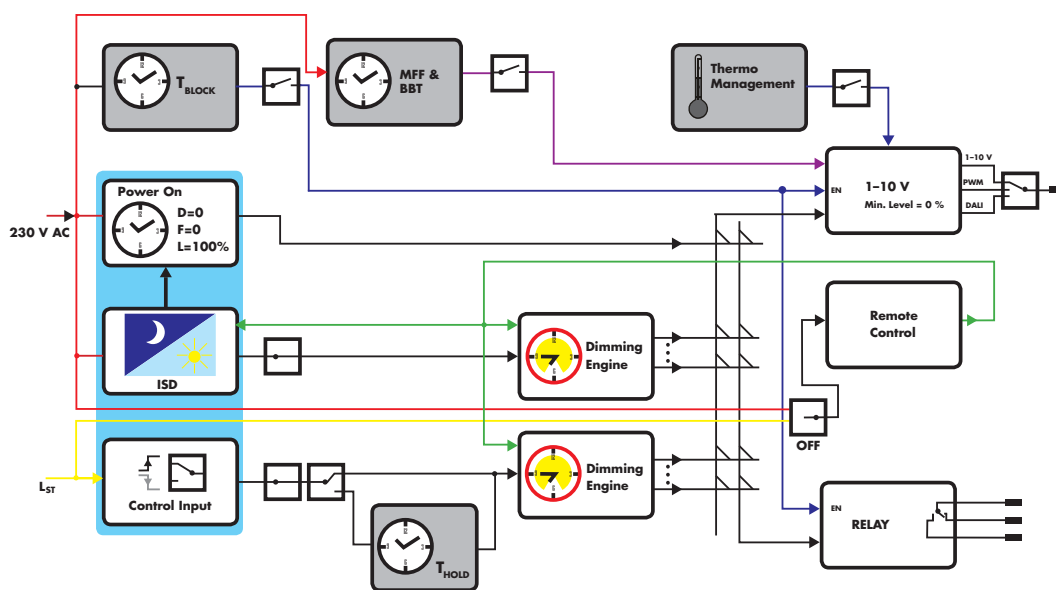

Remote parameterization by means of switching the power supply line on / off

Schaltplan für (11,20, 30)kW max Power	Schematic for Max Power 2kW
A1 TFR, EPR ... Empfänger, Lichtsensor	Standard control unit
K1 Hilfsrelais EL TAKO ER12-001-UC	Auxiliary relay EL TAKO ER12-001-UC
A3 iMCU Instell. Multifunctional Control Unit	iMCU Instell. Multifunctional Control Unit
A4 Hutschienen Netzteil	DIN-Rail Trafo
A5 MeanWell HDR-15-5 oder alternativ	MeanWell HDR-15-5 or alternativ
A1 nur mit entsprechender Firmware	Hand programming unit
Handbedienebene	only with the right firmware
	Manual switch

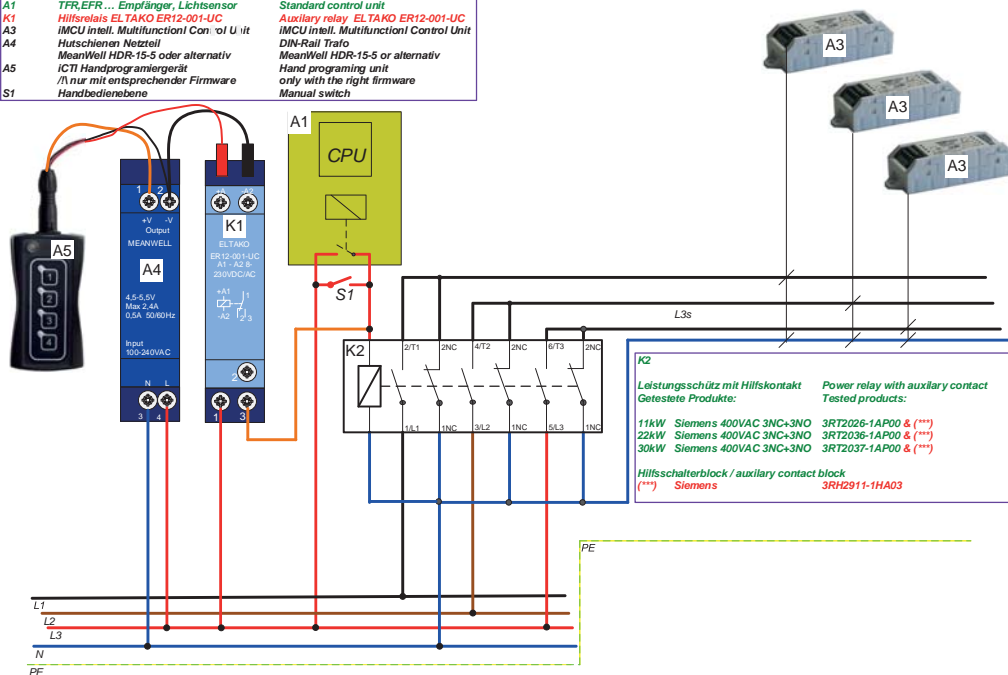

Leistungsschütz mit Hilfskontakt	Power relay with auxiliary contact
Getestete Produkte:	Tested products:
11kW Siemens 400VAC 3NC+3NO	3RT2026-1AP00 & (***)
22kW Siemens 400VAC 3NC+3NO	3RT2036-1AP00 & (***)
30kW Siemens 400VAC 3NC+3NO	3RT2037-1AP00 & (***)
Hilfsschalterblock / auxiliary contact block	
(***) Siemens	3RH2911-1HA03

The values specified in this data sheet may change due to technical innovation and without notice. For more detailed information visit www.vossloh-schwabe.com.

Light Controller iMCU

Magnetic ballasts for power reduction

The iMCU's separate relay contacts enable direct switching of a magnetic ballast's coil tapping point for power reduction purposes.

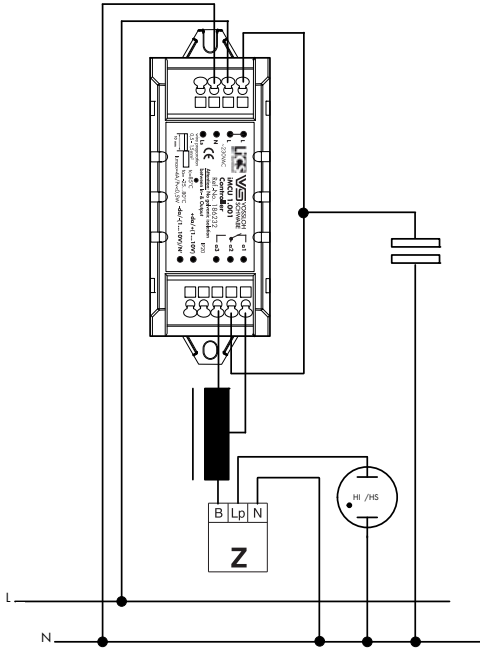

Connection of electronic ballasts with a 1-10 V / DALI control input

Apart from being able to address all commonly available ballasts, the iMCU also makes it possible to completely switch off electronic ballasts if connected to a switched lighting cable. In particular, this switch off means an important additional function for luminaires operated with 1-10 V electronic ballasts.

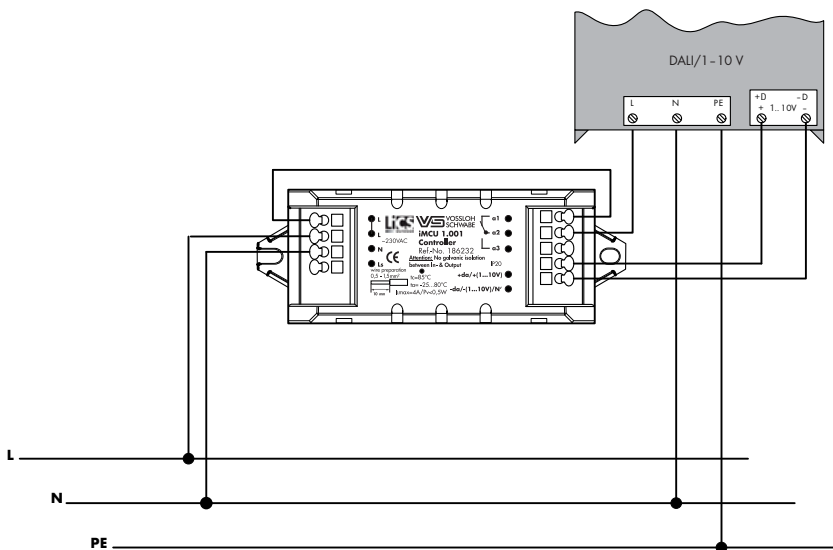

The values specified in this data sheet may change due to technical innovation and without notice. For more detailed information visit www.vossloh-schwabe.com.

Light Controller iMCU

Control via control input L_{ST} using motion sensor or control cable

The L_{ST} input is designed for 230 V AC. Different functions can be implemented depending on the selected configuration. When using a motion sensor, the lighting period can be defined in the controller. If motion is detected again during this period of time, the lighting period will restart for the specified time.

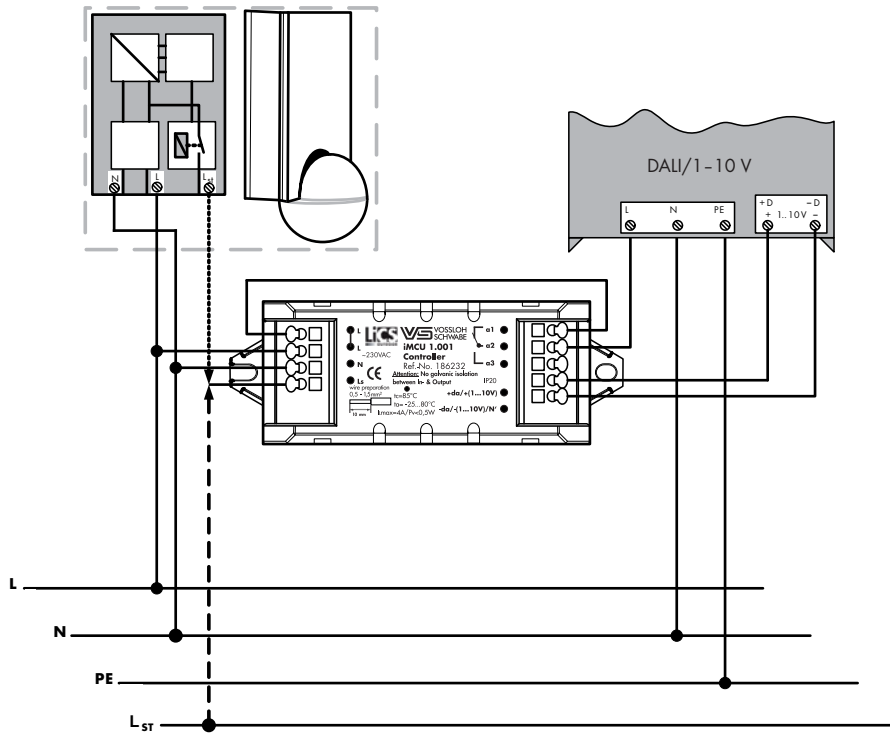

Connection

Cables used for making terminal connections must be stripped to a length of > 9.5 mm to enable easy connection and reconfiguration at a later date via the hand-held programming device.

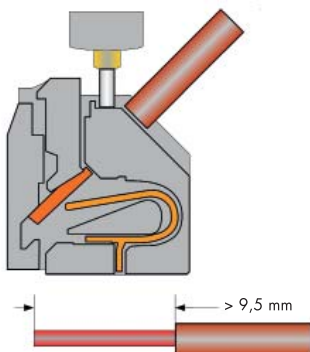

The values specified in this data sheet may change due to technical innovation and without notice. For more detailed information visit www.vossloh-schwabe.com.

Light Controller iMCU

Accessories

Hand-held device with software:
Intelligent Configuration Tool Interface (iCTI)
Control software and hardware for parameter
setting and updating of the iMCU controller
(Function diagram see p. 5.)

iCTI-USB adapter for configuring the iMCU
controller in combination with Microsoft®-PCs

Ref. No.: 186729 iCTI

Ref. No.: 186392 iCTI-USB



Extension option for iCTI

iCTI-R-/iMCU Extension Kit

For re-parameterizing and new-parameterizing
of the Astrodimm-level / Astrodimm-switching-times
via the power contactor in the sub-distribution
unit as well as the switching between summer- /
winter time and 2. Dim-Engine

- 5V power supply
- Eltako/isolation relays
- Adapter for iCTI

Ref. No.: 186730

For current software and the latest firmware for configuring and updating the iMCU controller go to
www.vossloh-schwabe.com

The values specified in this data sheet may change due to technical innovation and without notice.
For more detailed information visit www.vossloh-schwabe.com.

Light Controller iMCU

Sales text

The multifunctional, intelligent controller unit – which calculates a "synthetic" midnight – enables control of luminaires that are operated with magnetic ballasts (low-loss ballasts, low-loss ECO ballasts) and electronic ballasts with a 1-10 V/DALI interface and are used for street lighting and lighting in the vicinity of buildings. The iMCU enables control of luminaires that are connected to a switched lighting cable or a universal sensor via the control input. Ballasts fitted with a DALI interface are addressed using a broadcast command, which removes the need to commission the electronic ballast. The controller is extremely easy to configure and update. Based on the daily operating period, it is possible to set 10 switching times, each with an adjustable dimming sequence and dimming level. The 230 V AC control input permits superimposed use of up to 10 freely programmable dimming levels and dimming sequences. Furthermore, when used in sensor mode, the holding time for motion sensors can be freely and retriggerably defined. When used in areas outside of pedestrian crossings, the special configuration of the controller makes it possible to delay or bring forward the point in time when luminaires are switched off. The time delay, dimming sequence and dimming levels can be freely defined. Additional functions include delayed switching, thermal management, non-linear compensation of luminous flux decrease and change of the controller's parameter settings via switch on/off commands of the lighting cable.

Text for invitation to tender

Intelligent controller for managing luminaires in street lighting and lighting in the vicinity of buildings that are operated using magnetic ballasts (low-loss ballasts, low-loss ECO ballasts) as well as electronic ballasts with a 1–10 V/DALI interface. The controller is designed for use with a switched lighting cable or with an unswitched mains cable in combination with a sensor or with a control line. The controller features a potential-free relay contact to independently switch conventional and electronic ballasts on/off or to switch over magnetic ballasts with a coil tapping point. Electronic ballast control is effected using a configurable 1–10 V or DALI output. Electronic ballasts with a DALI interface are addressed using broadcast commands, which removes the need for any further configuration of this device class. Ballasts featuring a 1–10 V input are actively addressed. The minimum dimming value for 1–10 V/DALI electronic ballasts can be defined independently. Given typical use when connected to a switched lighting cable, the controller "learns" what time it is by itself based on the periods of time it was switched on during the first three days of operation; the detected time of day is then used to derive the real-life switching times. Up to 10 freely configurable times are available for setting the electronic ballast's dimming values. The switching status of the relay as well as dimming values and dimming sequences are individually configurable on the basis of the time set in the Parameters section. The 230 V AC control input can be used to influence internally calculated switching and dimming behaviour. The control input initiates up to 10 freely programmable dimming levels that impact the sequence of the relay's switching status, the dimming value and the dimming sequence. The relay, dimming value and dimming sequence can be set individually. The calculated dimming sequence and the dimming sequence that is initiated by the control input can be used in a superimposed manner. The decline in luminous flux over the lamp's service life can be compensated. Start and end values as well as lamp service life values can be freely configured. For new lamps, the higher-level dimming function can be switched off in dependence on lamp and lighting hours. The controller can delay switching on a luminaire and can switch it off earlier. Both dimming sequences and dimming levels are adjustable. External tools can be used to configure and update the controller. Power consumption during operation is < 0.5 W. The integrated temperature measurement enables thermal management in the luminaire irrespective of the electronic ballast or LED driver connected. Optionally, 15 randomly generated switch-on times, distributed over 150 ms, can reduce the inrush current of the drivers connected. Five interpolation points can be used to configure the luminous flux decrease of the lamp. Based on longitude and latitude, the controller automatically calculates summer and winter time with an accuracy of about 1 KW. The accuracy depends on the switching accuracy of the lighting cable (depending on weather in case of light sensors). Astro-dimming level parameters can be changed via special switch on/off sequences of the lighting cable.

The values specified in this data sheet may change due to technical innovation and without notice.
For more detailed information visit www.vossloh-schwabe.com.