

# COB LED MODULES

Dim2Warm  
1200 LM



## Dim2Warm COB – TUNEABLE WHITE

### WU-M-618-920/930

The Tuneable White LED modules enables colour temperature dynamic in the warm white range of 2000 K to 3000 K.

### Typical Applications

Built-in luminaires/general illumination

- Residential lighting
- Furniture lighting
- Retail lighting
- Downlights

### Dim2Warm COB Modules

#### ■ COLOUR TUNING BY DIM LEVEL

- 50 mA: 2000 K
- 350 mA: 3000 K

#### ■ NARROW COLOUR TOLERANCES: 3 STEP MacAdam

#### ■ HIGH COLOUR RENDERING INDEX: CRI > 90

#### ■ COMPACT SHAPE

- 13.5 x 13.5 mm
- LES: Ø 10 mm

## Dim2Warm COB

### Technical Notes

- LED module for integration into luminaires
- Dimensions / Light emitting surface (LES):  13.5x13.5 mm / Ø 10 mm
- Beam angle: 120°
- Use of external SELV constant current driver with analogue dimming (continuous; no PWM)



### Electrical Characteristics

at  $t_p = 25\text{ °C}$

Type	Typ. voltage DC				Typ. power consumption			
	50 mA V	100 mA V	200 mA V	350 mA V	50 mA W	100 mA W	200 mA W	350 mA W
WU-M-618-920/930	31.4	33.1	34.9	37	1.6	3.3	7	12.9

Voltage and power tolerance:  $\pm 10\%$

### Maximum Ratings

Exceeding the maximum ratings can lead to reduction of service life or destruction of the modules.

Type	Operation temperature range at $t_c$ point		Ambient temperature range		Storage temperature range		Max. allowed repetitive peak current (mA)	Max. allowed output voltage of drivers (V)
	°C min.	°C max.	°C min.	°C max.	°C min.	°C max.		
WU-M-618-920/930	-40	+80	-40	+40	-40	+100	450	60 (SELV)

### Operating Life

at  $t_p = 65\text{ °C}$

> 33,000 hrs. (L70/B10)

### Optical Characteristics

at  $t_p = 25\text{ °C}$

Typ. CRI:  $R_a$  90

Type	Ref. No.	Colour	Correlated colour temperature* K	Typ. luminous flux and efficiency ** and colour temperature												Photo- metric code
				50 mA			100 mA			200 mA			350 mA			
				lm	lm/W	K	lm	lm/W	K	lm	lm/W	K	lm	lm/W	K	
WU-M-618-920/930	<b>567964</b>	warm white	3000 → 2000	134	85	2000	316	95	2500	693	99	2800	1210	93	3000	9xx/347

\* Colour tolerance: 3 MacAdam | \*\* Production tolerance of luminous flux and efficiency:  $\pm 15\%$

**Minimum order quantity: 360 pcs.**

The values contained in this data sheet can change due to technical innovations. Any such changes will be made without separate notification.

## Dim2Warm COB

### Mechanical Dimensions

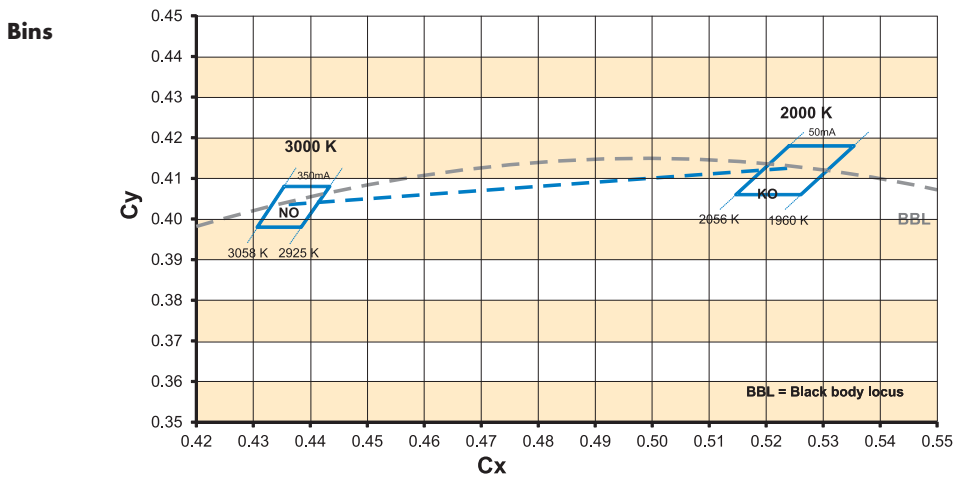
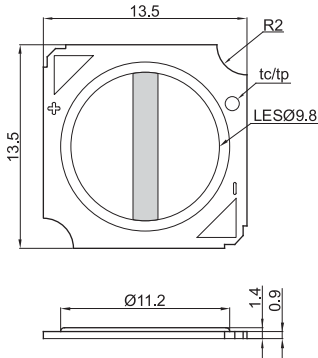

## LED Constant Current Drivers

Please visit our homepage for details for suitable LED constant current drivers: [www.vossloh-schwabe.com](http://www.vossloh-schwabe.com)

## Dim2Warm COB

### Assembly and Safety Information

Installation must be carried out under observation of the relevant regulations and standards. The LED modules are designed for operation within a casing or luminaire. Installation must be carried out in a voltage-free state (i.e. disconnection from the mains). The following advice must be observed; non-observance can result in the destruction of the LED assembly modules, fire and/or other hazards.

- ESD (electrostatic discharge) protection measures must be observed when handling and installing the LED modules. See VS's application notes on ESD protection.
- LED assembly modules must not be subjected to any undue mechanical stress, e. g.:
  - do not treat as bulk cargo
  - avoid shear and compressive forces during handling and installation
  - do not damage circuit paths
  - do not touch the yellow phosphorus layer
- The module must be fixed onto a thermally conductive surface.
- Safe operation only possible by the use of external constant current sources ( $I_{max}$ , see table "Electrical Characteristics").
- Operation only with power supply units that feature the following protection:
  - Short-circuit protection
  - Overload protection
  - Overheating protection
  - SELV (Safety Extra Low Voltage);  $U_{max} \leq 60$  V
  - Dimming method: analogue dimming (continuous; no PWM)
  - $I_{max}$  (see table "Maximum Ratings") must not be exceeded.
- When operating devices will be selected care has been taken to ensure that the maximum values (see table "Maximum Ratings") will not be exceeded.
- Please ensure the correct polarity of the leads prior to commissioning. Reversed polarity can destroy the modules.
- Safety regulations acc. to EN 60598 (or further standards) has to be observed if the maximum output voltage exceed the permitted touchable value.
- Measurement tolerances:
  - luminous flux:  $\pm 7$  %
  - voltage:  $\pm 3$  %
  - CRI:  $\pm 1$  %
- Maximum allowed number of switching cycles: 15,000
- A parallel connection of the modules is not allowed.
- To ensure problem-free operation, the specified maximum temperature at the  $t_c$  point (see "Operating Life") must be observed (and measured in accordance with EN 60598-1). To satisfy this point, it may be necessary to put measures in place to ensure any heat is dissipated from the PCB to the environment.
- In the event of outdoor applications or applications in damp locations, care must be taken to protect LED assembly modules against humidity, splashes and jets of water. Any corrosion damage resulting from humidity or contact with condensation will not be recognised as a defect or manufacturing fault. LED assembly modules are not specially protected against foreign bodies or dust. Depending on the type of application, further protection must be ensured to prevent dust and foreign bodies from entering.
- Operating LED modules in the presence of certain chemical substances or in chemically enriched (aggressive) environments can impair module functionality or even cause total module failure. Detailed information can be found in our "Chemical Incompatibility" PDF on our website [www.vossloh-schwabe.com](http://www.vossloh-schwabe.com)
- The photobiological safety of the LED modules must be classified into risk groups in accordance with EN 62471. Assessment in acc. with IEC/TR 62778: risk group 1

### Product Guarantee

- 5 years
- The conditions for the Product Guarantee of the Vossloh-Schwabe Group shall apply as published on our homepage ([www.vossloh-schwabe.com](http://www.vossloh-schwabe.com)). We will be happy to send you these conditions upon request.

The values contained in this data sheet can change due to technical innovations. Any such changes will be made without separate notification.